

OPTION 1 - FREESTANDING STEPS WITH GRANULAR FILL

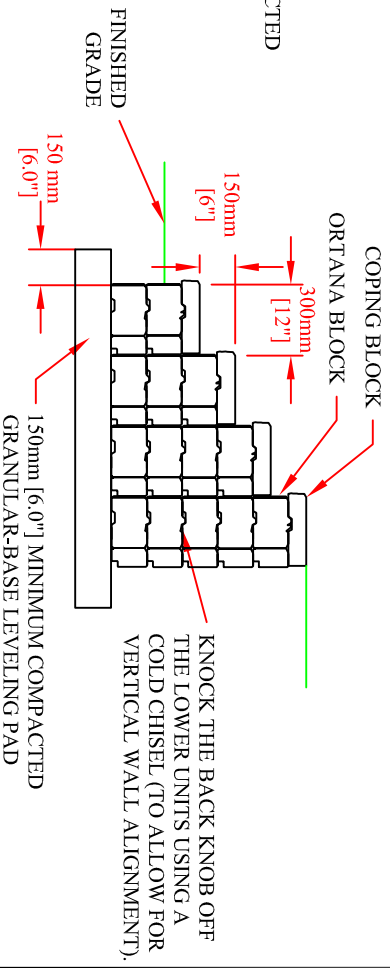

OPTION 3 - LEVELLING PAD WITH PRODUCT FILL

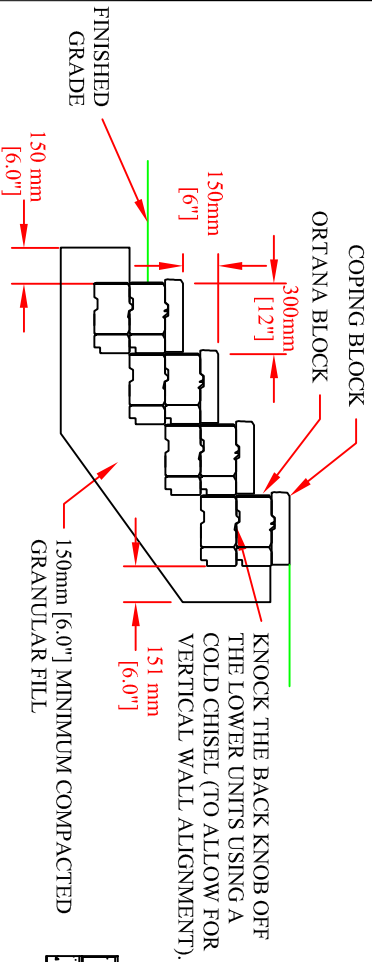

OPTION 2 - INTERLOCKING STEP RISER

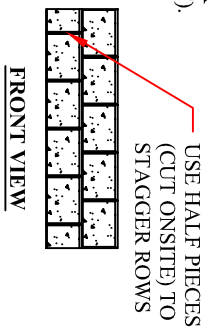

This graphic represents a preliminary, non site-specific design. If used for construction, a registered professional engineer must be retained to review & approve the design, confirm site conditions, and inspect construction.

**Ortana Retaining Wall System
Staircase Construction (Infill Options)**

OAKS
LANDSCAPE PRODUCTS